

SMALL CURRENT METER

MCM-02

NEW MODEL



Measuring water velocity in the small canal.



TÜV We are certified
ISO 9001:2008
 Certificate No. 01 100 072276
 Quality is our standard



Measuring water velocity in the small river.

The **AKIM MCM-02 Small Current Meter** is used for measuring the flow velocity at low water levels, e.g. in:

- Small Rivers
- Small canals
- Streams
- Lakes and seas
- Pressure pipes, falajs
- Natural water courses
- Laboratories

Small Current Meter is used worldwide for its proved quality, precision and reliability in measuring low water levels.

It is especially recommended for measurements in remote regions whenever a lightweight and handy measuring instrument is required.

Small Current Meter provides solutions for all velocity measuring applications. The highly precise, reinforced spindle bearing as well as an on- contact signaling system give the possibility for measuring flow velocities as from 0,025 m /sec. up to 5 m /sec.

Low starting speed of 0.025 m/sec. Minimum depth of water for using this instrument is approx. 4 cm.

Small Current Meters set the standard for liquid-flow measurement and without them hydrometry is not imaginable.

Fixing:

Small Current Meter can directly be fixed to a rod of 9 mm dia. A Relocating Device however, has proved to be a useful facility, which is designed as sleeve tube and is slid together with the current meter over the rod. For measurements from higher places (e.g. bridges) it is recommended, by means of the clamping piece to use a rod of 20 mm dia. with relocating device.

Measuring Ranges:

Depending on the pitch of the propellers used, different velocity ranges may be obtained. Besides, the propeller has a component effect. The angular degrees specified in the table show the extent of oblique flow up to which the propeller measures the true velocity value.

Within the stated ranges of oblique flow and velocity, the propellers follow the law of cosine with an accuracy of $\pm 1\%$ of the measured value.

Determination of Flow Velocity:

A calibration of the small current meter with the relating propeller is necessary in order to determine the water velocity "v" according to the equation;

$$v = k \cdot n + \Delta$$

v = flow velocity (m/sec.)

k = hydraulic pitch of propeller (m) determined by test runs in the modern hydraulic towing canal.

n = number of propeller revolutions per second

Δ = meter constant (m/sec.) determined by test runs in the modern hydraulic towing canal.

Since among current meters there are mechanical differences in the propellers as well as in the bearings, the constants "k" and " Δ " are found by specific tests in the modern hydraulic towing canal (Certificate of Calibration DSI - TAKK).

If desired, the calibration equation (relation between n and v) can also be supplied with fully calculated values compiled in a table (Velocity table- TAKK). The calibration values can be changed by the user (See user manual).

Rod:

9 mm. dia., 1,5 m. long, 3 sections in 50 cm. , numbered every 5 cm.

Connecting Cable:

2 m. long

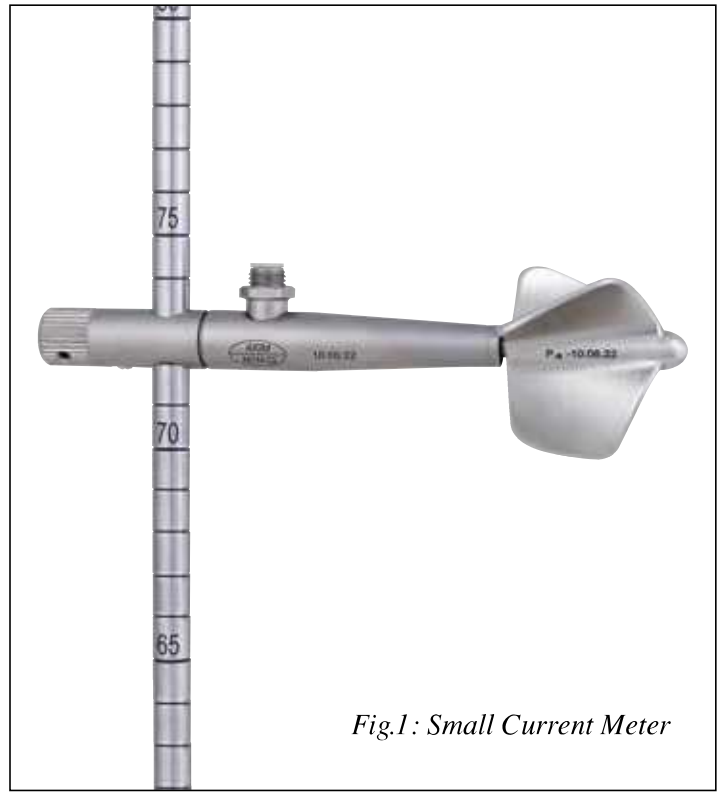

Fig.1: Small Current Meter



Fig.2: Small Current Meter with ground pin.

INSTRUMENT CASE (MCM-02)

Small Current Meter Metal Instrument Case includes basic unit:

Body Material:

Brass, nickel- plated), propellers, electronic counter, rods, and all its accessories.

Size of the instrument case:

54 x 18 x 8 cm.

Weight:

4,6 kg.

Option:

Extra rod, extra cable, extra oil.



Table:1

Propeller's Specifications

Propeller No	Propeller Diameter	Propeller Pitch	Min. Speed (m / sec.)	Max. Speed (m / sec.)	Component Effect	Material
1	50 mm	0.05 m	0.025 m	1,0	± 30°	Aluminium
2	50 mm	0.10 m	0.030 m	2,0	± 20°	Aluminium
3	50 mm	0.25 m	0.035 m	4,0	± 10°	Aluminium
4	50 mm	0.50 m	0.060 m	5,0	± 5°	Aluminium
5	30 mm	0.05 m	0.050 m	1,0	± 20°	Aluminium