



USH-8

Ultrasonic Snow Depth Sensor provides continuous data on the current snow depth



sommer

MESSTECHNIK



Properties and benefits

- » Continuous and contact-free ultrasonic snow depth measurement
- » Reliable sensor for extreme conditions
 - Robust sealed ceramic membrane
 - Correct measurement during snowfall and snow drift
 - Protective shield against ice and snow hangings
 - Integrated lightning protection
- » High measuring accuracy
 - Integrated temperature compensation
- » Energy-saving sensor operation
 - „Standby“ between the measuring phases
 - Optimum for solar-powered stations
- » Simple sensor integration
 - Analogue and digital interface
 - Parameterization via hyper terminal

Introduction

Basis of snow depth measurement

The measurement of snow depth is an important parameter for the measurement of the snow cover in the terrain. Its formation is subject to strong variance, based upon time and space factors. Influencing factors here are the development of snow cover, under the influence of further climatic events (air temperature, wind, global

Principle and accuracy of meas

The sensor's principle of measurement deals with the transit-time measurement of an ultrasonic pulse. The sensor transmits several energy-charged pulses to the snow cover and subsequently receives its reflected signals. Based upon the required transit time of the ultrasonic signals, the USH-8 sensor calculates the current snow depth. The processing time of the ultrasonic pulses here is enormously influenced by the air temperature. For this reason, the snow depth sensor also possesses integrated temperature compensation. This takes into account the influence of the air temperature on the processing time of the ultrasonic signals, in the calculation of the snow depth. The calculation takes place in the sensor, so that the output signal provides the already converted snow depth. In this manner, optimum measuring results are achieved, with an accuracy of 0.1% (FS).

Reliable sens onditions

The USH-8 sensor is also highly reliable during extreme environmental conditions allowing also very well long-term reliability of the measured data.

This occurs with energy-charged 50 kHz ultrasonic pulses, and it also provides reliable results under the most difficult reflection conditions, as in the case of powder and new snow cover. By means of energy-charged ultrasonic pulses, the icing of the ultrasonic membrane and sensor head is

Ene viding sensor operation

The USH-8 sensor automatically switches between measuring and "standby" operation. The data logger must not switch the sensor on and off, and in this manner a highly energy-saving operation is achieved. For the transfer of measured data, the USH-8 is activated by the data logger via "transfer pin". For the measuring operation of the day, only 0.5 Ah is required

radiation), the characteristics of the land, as well as the spatial distribution of precipitation in an area. Because of these factors, the selection of a suitable location for measurement is decisively responsible for whether this is representative for an area or not.

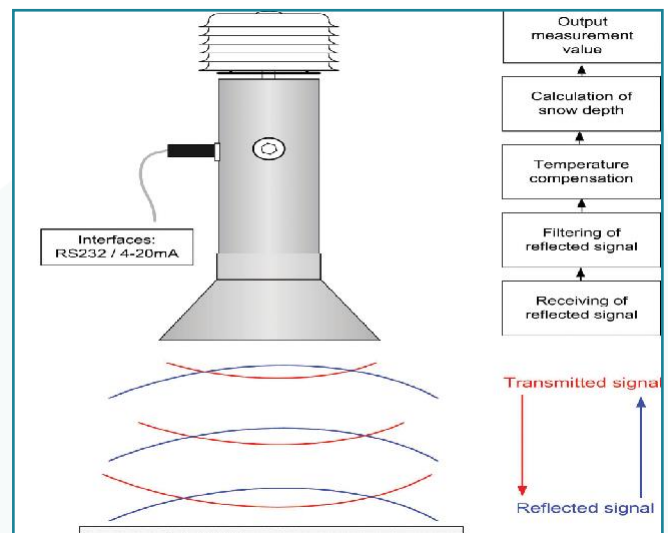

Fig. 1: Signal processing by the USH-8 snow depth sensor.

hindered, and an automatic de-icing is carried out. Moreover, an intelligent measured signal conversion is compensated, by means of filtration of snow and rain precipitation, occurring in the signal path of the ultrasonic signals during measurement. In this manner, correct measurement is also assured during precipitation, and there are no negative effects on the results of measurement.

per minute. Between the measuring phases, the sensor automatically switches to standby operation with <1 mA consumption. With this property of energy economy, the sensor is optimally suited for self-sufficient measuring stations using with solar power supplies.

Extract the measuring location and assembly

Selection of the measuring location

The right selection and positioning of the measuring location is of very great importance. The field of measurement to be recorded should be most preferably flat, protected from wind and secured against avalanches. Steep hillsides, hollows, terrain edges or large rocks in the immediate vicinity of the measuring location should be avoided. Steeply sloping fields of snow harbour the danger that the snow cover could begin to slide, thereby falsifying the measuring results. To ensure a problem-

Assembly

The sensor has already been calibrated (temperature compensation) and preconfigured prior to delivery. In addition to the customer-specific settings (interface, protocol, ...), the zero point parameter for the location must be set after the installation. This is implemented easily and comfortably via the Windows Hyperterminal.

The optimal mounting height of the sensor is 3m or more. The maximum permissible mounting height equals 11m. Here it is important to take into account that the diameter of the field of measurement is increasing with the applied measuring height (see fig. 2). In order that the field of measurement is not disrupted, two distances must be kept in mind when setting up the station. Firstly, there is the distance between the sensor and the field of measurement, and secondly, there is the distance between the sensor and pole / pole base. When the field of measurement is disrupted, this can lead to undesired reflections, and therefore to incorrectly measured data. Objects in the vicinity of the field of measurement (i.e. terrain edges, buildings, ...) also create snow drifts, thereby causing undesired disruptions of the field of measurement.

The material of the field of measurement's surface must be representative of the area to be examined, since differing materials produce differing defrosting capacities, and may thereby lead to undesired disruptions of the field of measurement. For measurement in natural terrain, we recommend fine gravel or crushed rock for the preparation of the field of measurement's surface.

Simulation into existing weather stations

The measured value of the USH-8 snow depth sensor can be integrated into an already existing station, using either an analogue (4-20mA signal) or a digital interface (RS 232). In addition, the provided pole-holding fixture allows for easy assembly.

free measurement, the sensor must be aligned parallel to the ground. A minor incline of the ground can be compensated for by a correct alignment of the sensor, using the holding fixture provided. Furthermore, the expected snow depth at the location should be estimated, in order to assure a suitable mounting height for the sensor.

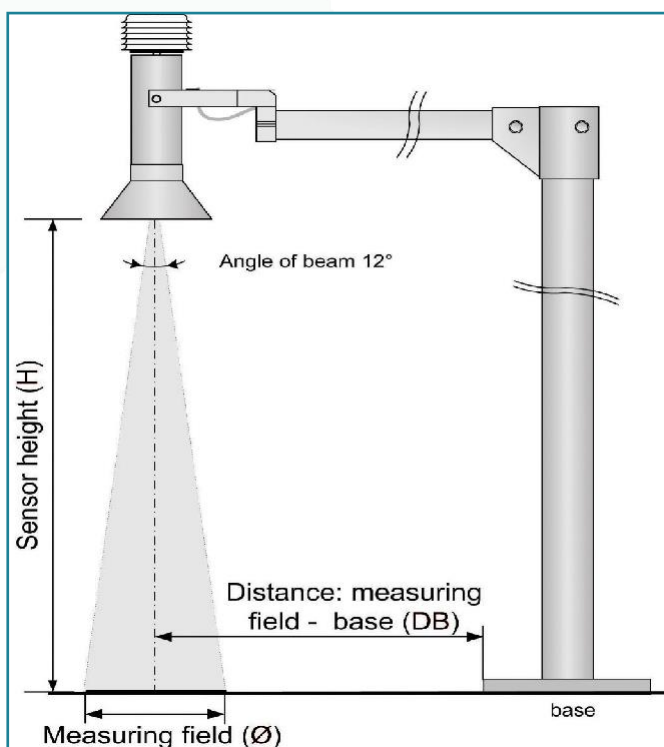

Sensor height H (m)	Measuring field Ø (m)	Minimum distance DB (m)
2	0.4	1.0
3	0.6	1.2
4	0.8	1.4
5	1.1	1.6
6	1.3	1.8
7	1.5	2.0
8	1.7	2.2
9	1.9	2.4
10	2,1	2,6
11	2,3	2,8

Fig. 2: Overview of the assembly dimensions of the USH-8 sensor.

Technical Data

General	
Power supply	Supply voltage: 10.5 ... 15 VDC Power input: max. 200 mA (Measuring phase about 3 sec); <1 mA (Standby) Power consumption: 0.5 Ah / day (with measuring interval of 1min)
Operating temperature	-40 ... 60 °C
Housing	Dimensions: Ø 110 mm, length 350 mm Material: anodized aluminium Weight: 1,6 kg
Protection	IP 66
Lightning protection	Integrated lightning protection (discharge capacity 0.6 kW)

Snow depth measurement	
Measurement range	0 ... 10 m
Minimum distance to the maximum expected snow depth	1 m
Accuracy	0.1 % (FS)
Resolution	1 mm
Measurement principle	Ultrasonic (Frequency 50 kHz; Angle of reflected beam 12°)

Integrated compensation of the air temperature	
Temperature sensor	Integrated air-temperature sensor in self-venting radiation shield
Measurement range	-40 ... 60 °C
Resolution	0.1 °C
Non-linearity	≤ 0.15 %

Accessories (not included in the price)	
Pole arm	Pole arm with tilting function for comfortable sensor assembly and maintenance: Holder for pole Ø 114 mm, Hot-dip galvanized, Dimensions: Ø 61 mm (2"), length: 1600 mm

Interfaces	
Analogue	Snow depth measurement 4 - 20 mA signal Resolution: 12 Bit Max. load: 300 Ω
Digital	Snow depth measurement; air temperature; quality flag RS 232; serial interface Protocol: Various ASCII formats

Packaging	
Carton (mm)	Dimensions: 475 x 225 x 255 mm Weight: approx. 3,4 kg (gross)